

Modernization of Control Systems for Research Facilities

Klemen Vodopivec

Karen S. White

10/10/2023

for ICALEPCS 2023



EXPERIENCE
ORNL
MEET. EXPLORE. LEARN.

ORNL is managed by UT-Battelle, LLC for the US Department of Energy



U.S. DEPARTMENT OF
ENERGY

Spallation Neutron Source @ Oak Ridge National Laboratory



Operational goals
– 5000 hours/year,
>90% availability



- World's most powerful pulsed neutron source, SNS was built by a consortium of six US DOE laboratories
- Started operations with EPICS based control system, 2006
- In final phase of Proton Power Upgrade project to double beam power (1.4MW => 2.8 MW)



Motivation

- Sponsor driven goals for availability > 90% implies >99.% needed for Control Systems
- Lifetime of the facility (50+ years)
- ~600,000 control points for ~3000 devices – all must be working to operate the accelerator and target facilities
- Reduce or avoid technical debt

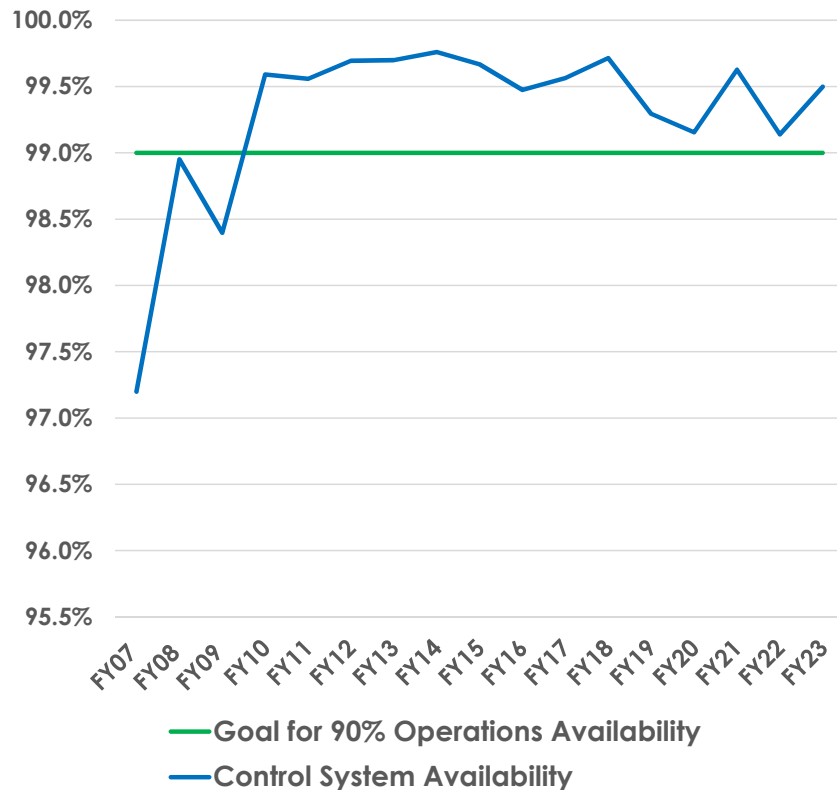

Ownership

- Everything you own has a cost of ownership
- Measured in dollars or labor or both
- Regular maintenance
- End of life renewal
- The cost of not addressing this caretaking likely means the thing will degrade over time
- Even with maintenance, most things have a fixed lifetime



Including your control system

Control system care taking – keep systems at top performance

- Spares management
- Fault precursor monitoring
- Planned, preventative maintenance
- Obsolescence driven upgrades
 - Hardware
 - Software

This starts even before system completion

High Availability and Cyber Security

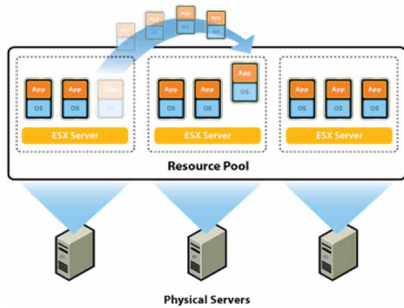

Virtualization provides encapsulation, partitioning, hardware independence

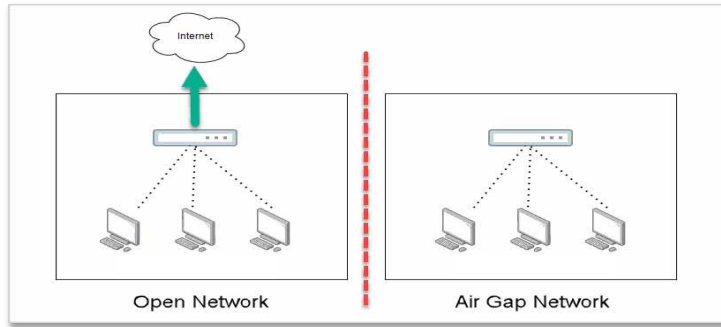

Managed, monitored and audited MFA-enabled remote access

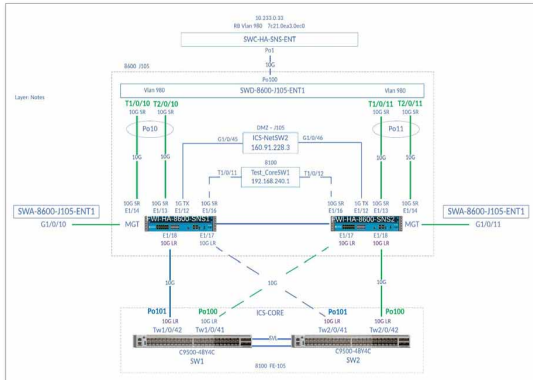

Device, link, power source redundancy

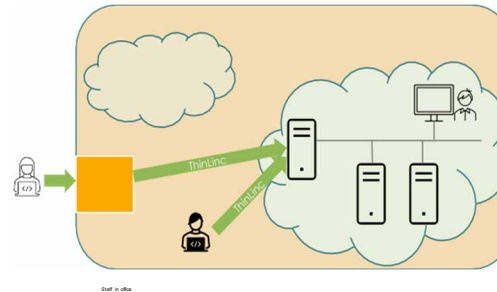

Managed, monitored and audited MFA-enabled remote access



Updated cyber security assessment and practices

Network Infrastructure Upgrades

- Replaced ~75% of network equipment in last 2 years
- Upgrading to 10/25 Gbps
- Optimized configuration
- Monitoring system health

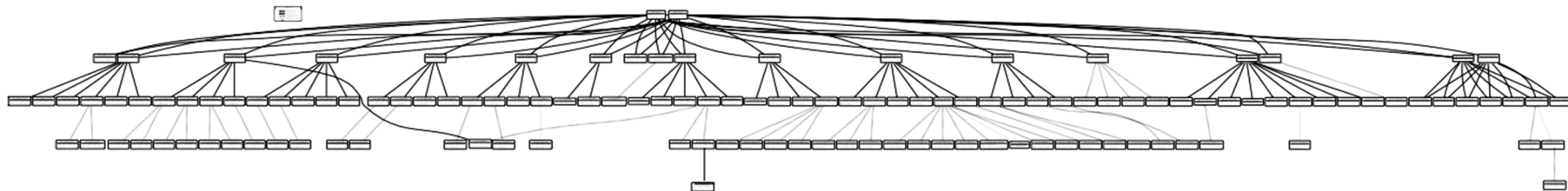
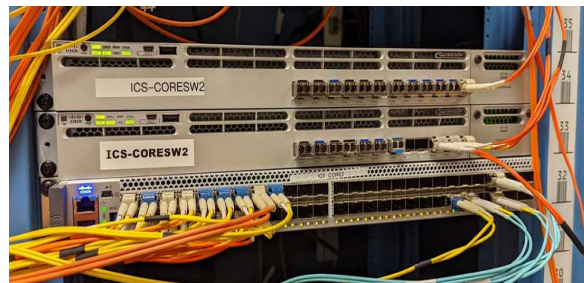

Transition of CPU architectures

- Intel architecture moved to 64-bit (Linux)
 - Requires software to be re-built and testing
 - For slow controls applications and operator interfaces
- Motorola VME PowerPC CPUs migration to Intel x86_64 platform (VxWorks)
 - For embedded, IO driven or real-time applications

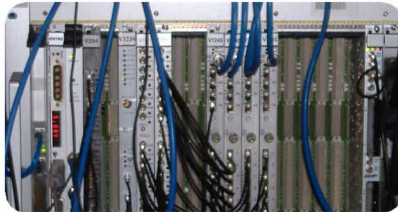

Electronics Lifetime and Hardware Obsolescence

- Managing and maintaining general purpose Linux servers, embedded CPUs, custom electronics, ICS network equipment
- Replacing equipment at 80% of expected lifetime
- Regular preventive maintenance supports realization of vendor specified lifetime
- Supply chain issues demand diligent restocking, pre-purchasing spares to reduce risk

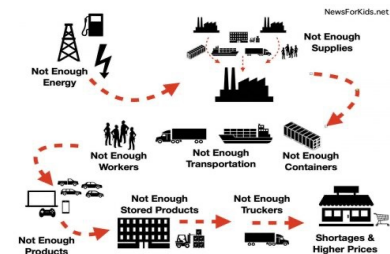
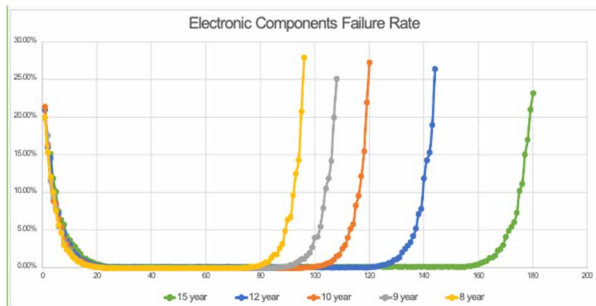

Conclusion

- Even before a control system is complete, constant work is required to ensure high availability and support system requests for additional functionality
- Control systems need performance margin to add extra devices or new features (compute power, storage, developers) as the machine evolves
- It pays to analyze system performance and trends to inform the use of limited resources
- Constant work to minimize the accumulation of technical debt
- This all takes time and requires procurements, so budget can be the limiting factor